

Face to face dimension to DIN 3202-F6
 Flanges and drilling to ISO 7005-2 (EN 1092-2: 1997, DIN 2501)

Use:

For sewage to max. 70°C.

Tests:

Pressure test:

Seat: 1.1 x PN
 Body: 1.1 x PN

Options:

NBR rubber liner for check valve standard

Materials:

Body and cover	Ductile iron, GGG-40 to DIN 1693 (BS 2789)
Coating	Electrostatically applied epoxy resin to DIN 30677
Cover gasket	NBR O-ring
Ball	Polyurethane
Bolts, nuts and washers	Stainless steel, A2



Face to face dimension to DIN 3202-F6
 Flanges and drilling to ISO 7005-2 (EN 1092-2: 1997, DIN 2501)

Component list

- | | |
|--------------------|---------|
| 1. Cover | 4. Body |
| 2. Bolt/nut/washer | 5. Ball |
| 3. Gasket | |

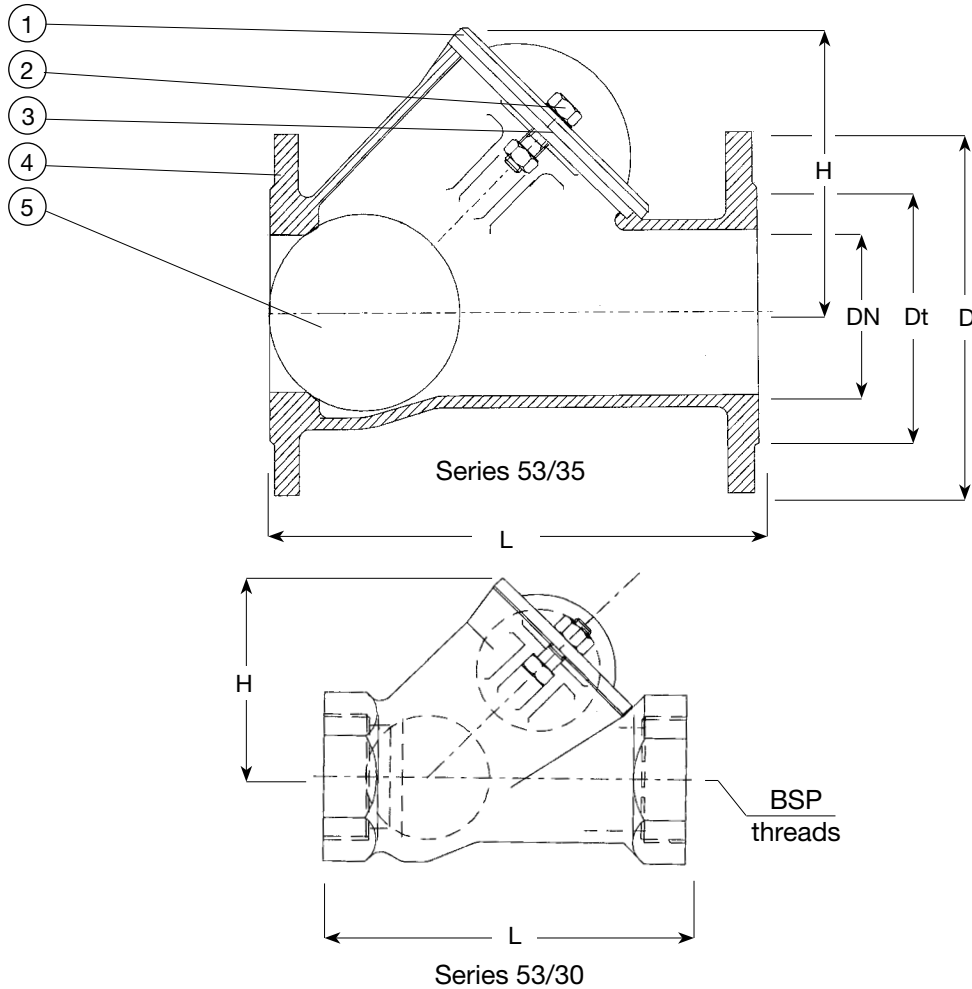

Ref. nos.	DN	L mm	BSP thread	Dt mm	D mm	H mm	D ball mm	Weight kilos
53-032-309607*	32	140	1 1/4"	-	-	83	48	1.9
53-040-309607*	40	140	1 1/2"	-	-	83	48	1.9
53-050-309607*	50	180	2"	-	-	101	60	2.8
53-050-351607	50	200	-	98	165	101	60	7.4
53-065-351607	65	230	-	118	185	148	95	11.7
53-080-351607	80	260	-	133	200	148	95	12.7
53-100-351607	100	300	-	159	220	182	120	17.5
53-125-351607	125	350	-	183	250	251	175	30.5
53-150-351607	150	400	-	209	285	251	175	37.5
53-200-350607	200	500	-	268	340	333	240	70.0

* With internal thread.