

AVK SERVICE CONNECTION VALVE WITH PE-PIPES PN 10 36/8X

To DIN 3352 part 4 and DIN 3230 part 4
For fusion welded installation in PE-water pipes to BS 3284 (DIN 8074, DS 2119)

Use:

For water and neutral liquids to max.
70°C
PE-pipe material to max. 20°C

Tests:

Valve Hydraulic test to DIN 3230 part 4:
Seat: PN
Body: 1.5 x PN
Operating torque test

Optional extras:

Handwheel
Extension spindle
Stem cap
Foundation

Materials:

Body and bonnet	Ductile iron, GGG-50, to DIN 1693 (BS 2789 grade 500 - 7)
Coating	Electrostatically applied epoxy resin to DIN 30677
Stem	Stainless steel, DIN X 20 Cr 13
Stem sealing	NBR wiper ring, 2 NBR O-rings inside and 2 outside a plastic bearing, EPDM rubber manchette
Wedge	Dezincification resistant brass, CZ 132 to BS 2874 vulcanized with EPDM rubber
Thrust collar	Dezincification resistant brass, CZ 132 to BS 2872
Bonnet bolts	Stainless steel A2, sealed with hot melt
Bonnet gasket	EPDM rubber
Sleeves	St 52 to DIN 2448/1629
Shrink hose	Plastic to DIN 30672
Pipes	PE-water pipes PN 10 to BS 3284 (DIN 8074, DS 2119)

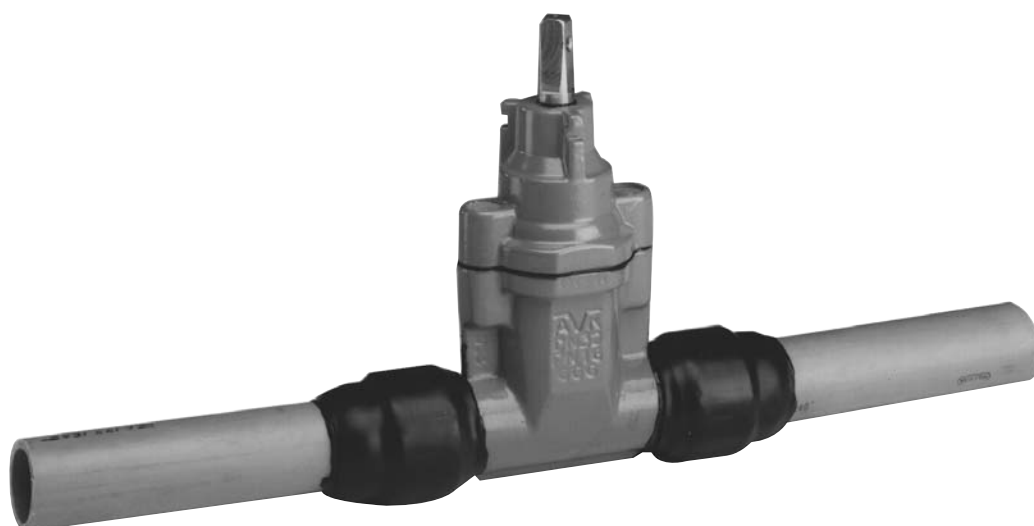

To DIN 3352 part 4 and DIN 3230 part 4
 For fusion welded installation in PE-water pipes to BS 3284 (DIN 8074, DS 2119)

Component list

- | | |
|--------------------------|------------------|
| 1. Stem | 8. Bonnet bolt |
| 2. NBR wiper ring | 9. Bonnet gasket |
| 3. NBR O-ring | 10. Wedge |
| 4. Bearing | 11. Body |
| 5. Bonnet | 12. Sleeve |
| 6. Thrust collar | 13. Shrink hose |
| 7. EPDM rubber manchette | 14. Pipe |

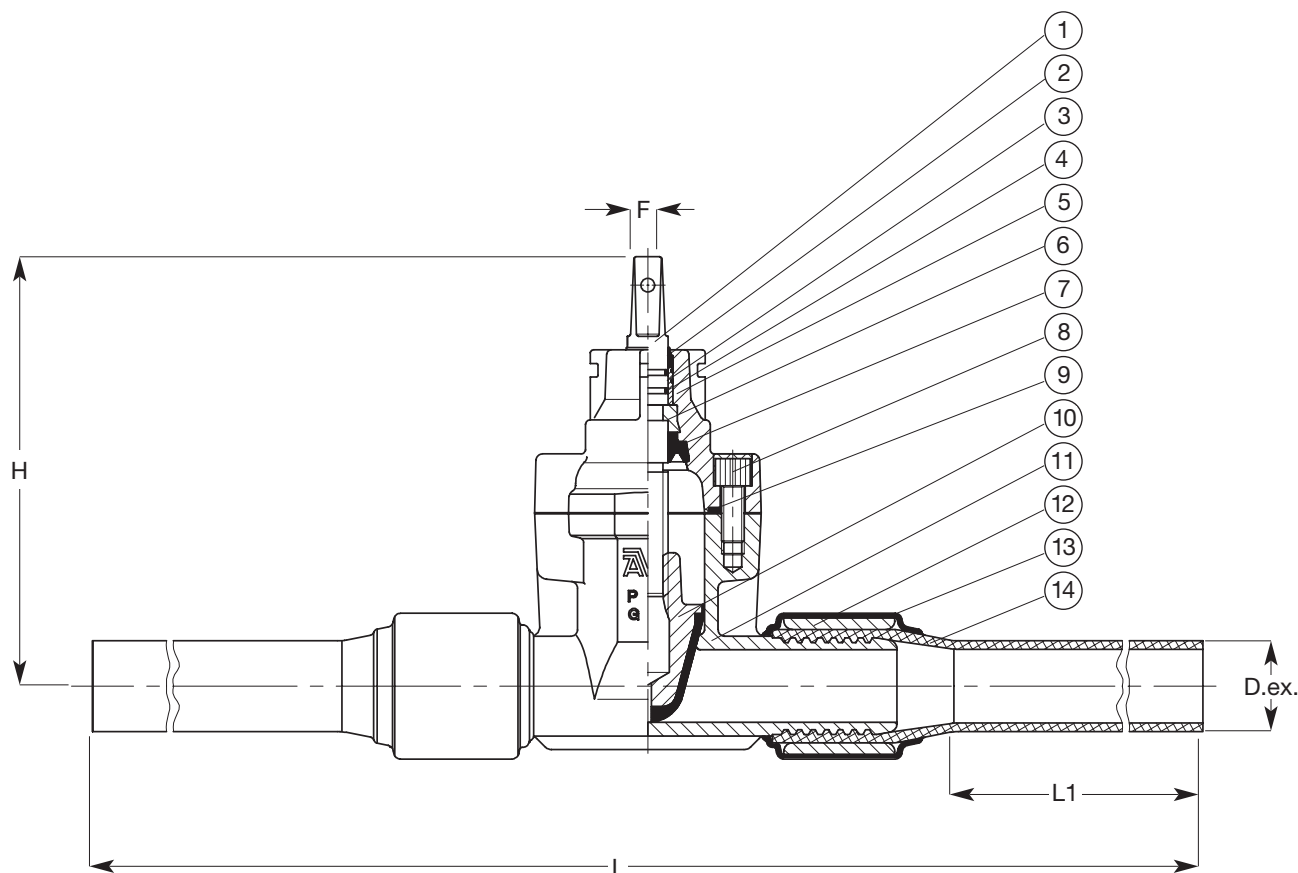

Ref. nos.	DN	PE-pipe D.ex. mm	L mm	L1 mm	H mm	F mm	Weight kilos
36-032-80103	25	32	800	300	180	13	5.1
36-040-80103	32	40	850	300	190	13	5.5
36-040-80103	32	40	1550	300/1000	190	13	6.0
36-050-80103	40	50	880	300	203	13	5.6
36-063-80103	50	63	880	300	213	13	6.8